

PAWRATES COVE



Quilt design by Linda Fitch and Linda Ambrosini featuring fabrics from the "Pawrates Cove" collection by L. A. Berry for Hoffman California Fabrics



Free pattern available from www.hoffmanfabrics.com

Quilt Size 62" x 73"

PATTERN REVISED
JUNE 27, 2013

HOFFMAN FABRICS
CALIFORNIA-INTERNATIONAL

“Pawrates Cove”

by Hoffman California Fabrics

Quilt Design by Linda Fitch and Linda Ambrosini

Yardage Chart

Style	
L4141 4-Black	1 1/2 yards
L4141 134-Parchment	1 1/2 yards
J9000 3-White	1/2 yard
J9000 4-Black	3/4 yard
J9000 16-Sky	3/4 yard
J9000 18-Royal*	7/8 yard
J9000 48-Gray	1/8 yard
J9000 62-Sand	2 yards

*Yardage includes binding.

BACKING: Coordinate of your choice. 4 5/8 yards (1 kit); 55 1/2 yards (12 kits)



L4141 4-Black



L4141 134-Parchment



J9000 3-White



J9000 4-Black

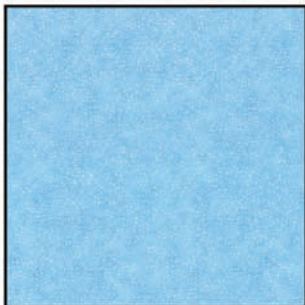

J9000 16-Sky

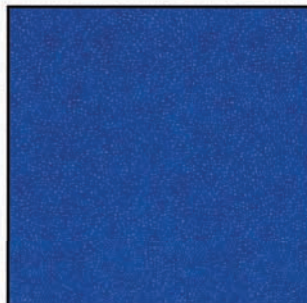

J9000 18-Royal

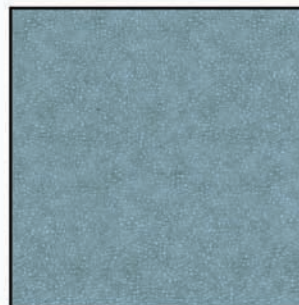

J9000 48-Gray

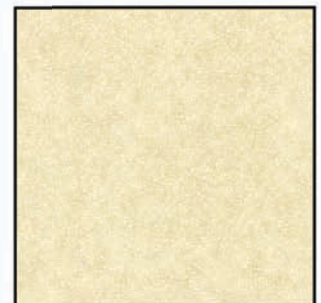

J9000 62-Sand

View swatches and download quilt patterns at www.hoffmanfabrics.com

Pawrates Cove

Designed by Linda Fitch
Instructions by Linda Ambrosini

Finished Size 62 x 73 inches
Paper piecing knowledge required

Fabric requirements:

Fabric L4141-134	Parchment Cats	1 ½ yds	
Fabric L4141-4	Black Cats	1 ½ yds	
Fabric J9000-62	Sand	2 yds	
Fabric J9000-16	Sky	¾ yd	
Fabric J9000-18	Royal	7/8 yd	binding included
Fabric J9000-4	Black	¾ yd	
Fabric J9000-3	White	½ yd	
Fabric J9000-48	Gray	1/8 yd	

Cutting Instructions:

Fabric L4141-134 Parchment Cats
~ Fussy cut eight 10 ½" squares

Fabric L4141-4 Black Cats
~ Fussy cut six 10 ½" squares

Fabric J9000-62 Sand
~ Cut five 10 ½" x WOF strips, sub cut into nine 10 ½" squares seventy one 10 1/2 " x 1 ½" sashing rectangles and one center applique circle, template B. The remainder is used to paper piece the wave block.

Fabric J9000-16 Sky
~ Cut two 1 ½" x WOF strips, sub cut into forty two 1 ½" squares for the sashing cornerstones. Cut one 3 ½" x WOF, sub cut into nine 3 ½" squares for making the ship's half square triangle. Cut one 3" x WOF strip, sub cut into twelve 3" squares for the ship's sky. The remainder of the fabric is used while paper piecing the compass and wave blocks.

Fabric J9000-18 Royal

~Cut one strip 3" x WOF, sub cut into three 3" x 10 1/2" rectangles for the water in the ship block. Cut seven 1 1/2" x WOF strips to be used as the inner border. Cut seven 2 1/4" x WOF strips to be used as the quilt's binding. The remainder of the fabric is used in paper piecing the compass and wave blocks.

Fabric J9000-4 Black

~Cut one 3 1/2" x WOF, sub cut into three 3 1/2" squares for making half square triangles and three 3" x 5 1/2" rectangles for the ship's hull. Cut seven 2" x WOF strips to be used as the outer border. The remainder of the fabric will be used to create the treasure map.

Fabric J9000-3 White

~ Cut one 3 1/2" x WOF strip, sub cut into six 3 1/2" squares to be used as half square triangles for the ship's sails. The remainder is used while paper piecing the wave blocks.

Fabric J9000-48 Gray

~Used for paper piecing the compass block.

Constructing the novelty blocks:

For this quilt, construct 3 Pawrate ship blocks, 4 wave blocks and 1 compass block.

Pawrate Ship blocks: Make 3. Reference the ship block line drawing. Half-square triangles make the sails and the hull sides of our ship. Draw a diagonal line across all eight Sky fabric 3 1/2" squares. Pair each Sky fabric square with either a White or Black 3 1/2" square. With right sides together, sew each pair a scant quarter inch off both sides of the drawn line. Cut apart and press the seam allowance towards the darker fabric. These half square triangles are oversize, trim to 3". Lay out all pieces of the ship to the line drawing. Sew into rows and then join the rows to complete the ship. At this point, the block should measure 10 1/2" square.

Wave blocks: Make 4. These blocks are paper pieced. Remember when paper piecing the pattern is reversed to the image you will achieve. Tape together the two halves of the wave unit. Your paper piecing pattern should measure 10 1/2" square to the outside dotted lines, Piece #1 in the wave is actually a 4-patch made up all four fabrics used in the wave. Therefore, first make these 4-patches from 1 3/4" squares of each fabric sewn together. Orient this pieced 4-patch onto piece #1 in the wave block. Then continue on, just like you would normally paper piece.

Compass block: Four wedge sections will need to be paper pieced. Next, join the four wedges together to create the circular compass. Turn under the outer raw edge $\frac{1}{4}$ ". Lightly score the 10 $\frac{1}{2}$ " Sand background piece, folding in half once and then again, in the opposite direction. Match the darker blue points (of compass) to the folds of the background piece and applique in place. Applique the 2 $\frac{1}{2}$ " circle, template B, to the center of your compass using your favorite method.

Treasure Map markings: Included in this pattern is the Pawrate flag. Copy this artwork onto a sheet of printable fabric (found at your local craft/quilt shop). Cut out and appliqué the flag onto one of your 10 $\frac{1}{2}$ " Sand squares. The "X" and the trail were created from the J9000-4 Black fabric backed with fusible web. The artwork for the "X" is given and the trail was cut from $\frac{1}{2}$ " wide strips of the fusible web backed fabric. I did not appliqué the trail until after I had completed sewing the blocks so that the trail seemed to line up. The map's trail extends across both the blocks and sashing where the fabrics were the same.

Constructing the quilt:

At this point all the blocks and sashing should be cut or pieced. Organize their placement per the color picture. Sew into rows. Join the rows to complete the quilt center.

Add the borders, quilt and bind.

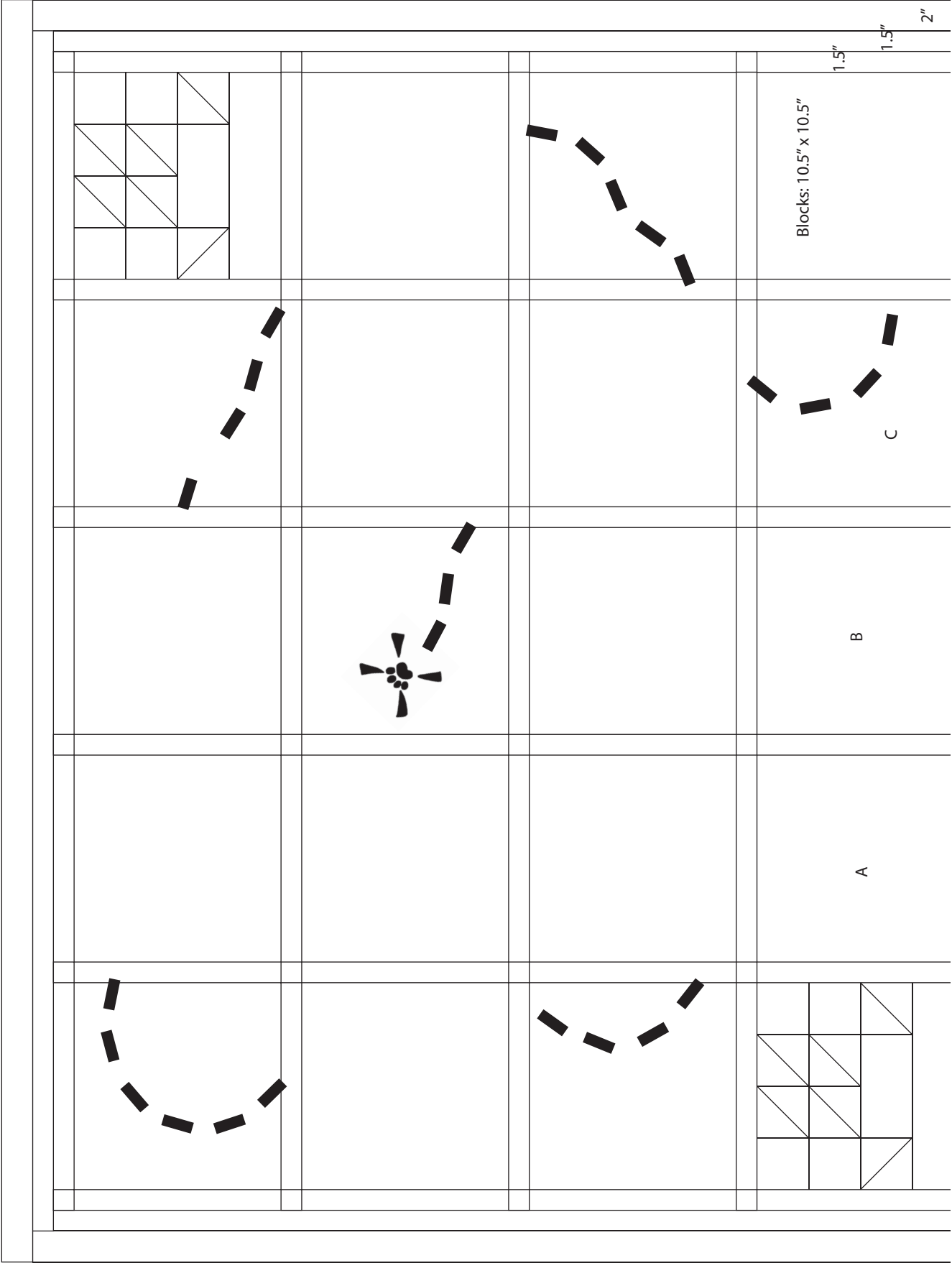

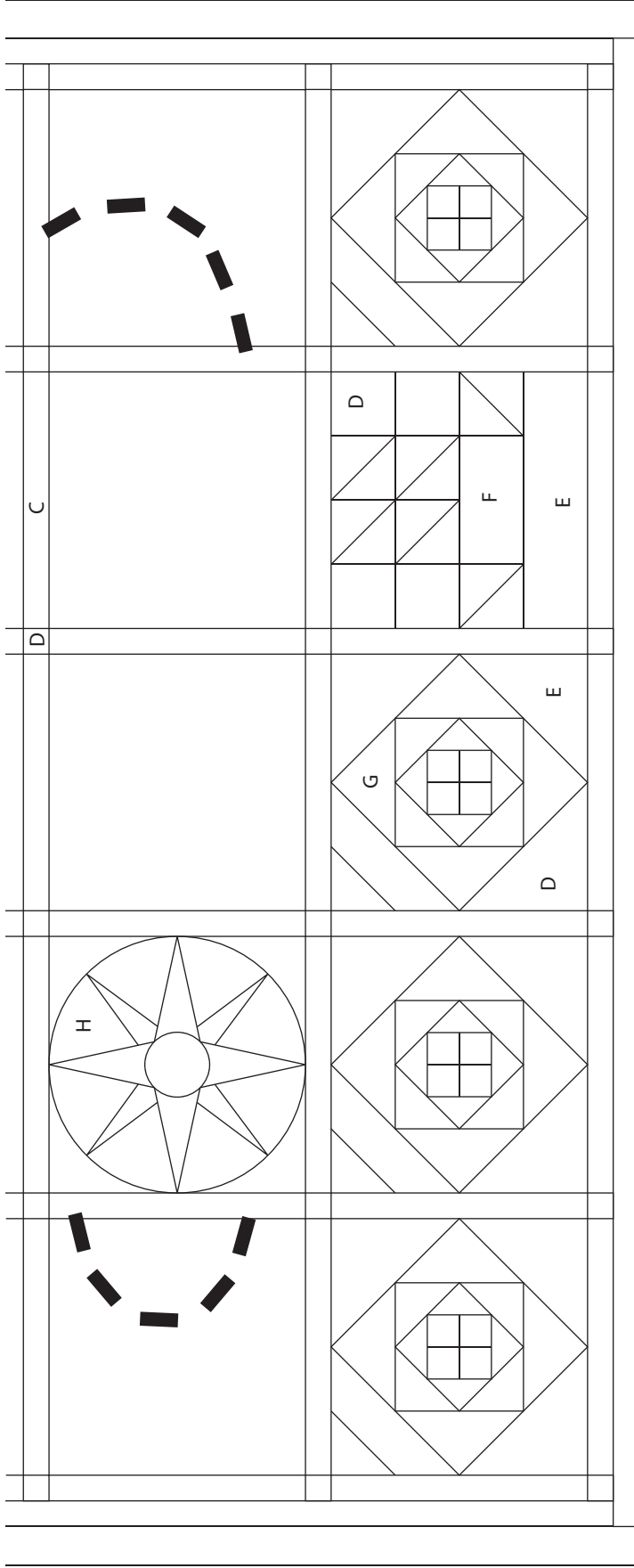

Fabric	Style #
A	L4141 Black #4
B	L4141 Parchment #134
C	J9000 Sand #62
D	J9000 Sky #16
E	J9000 Royal #18
F	J9000 Black #4
G	J9000 White #3
H	J9000 Gray #48

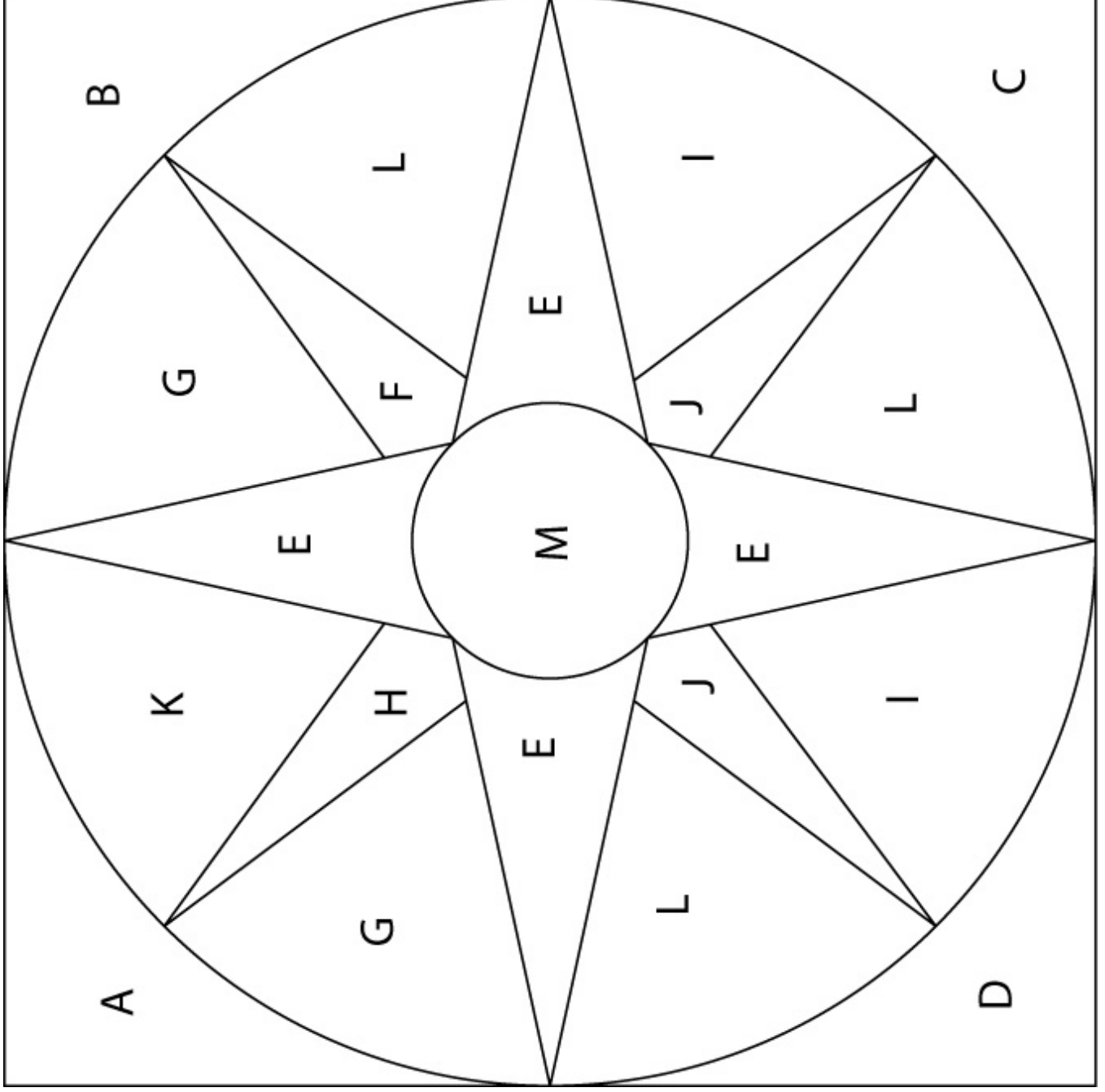

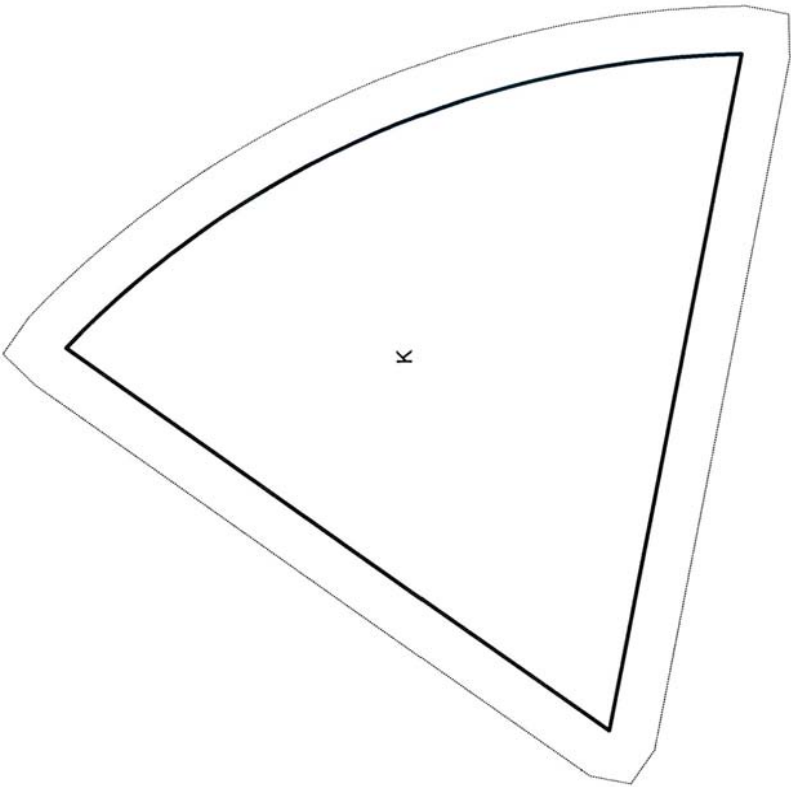
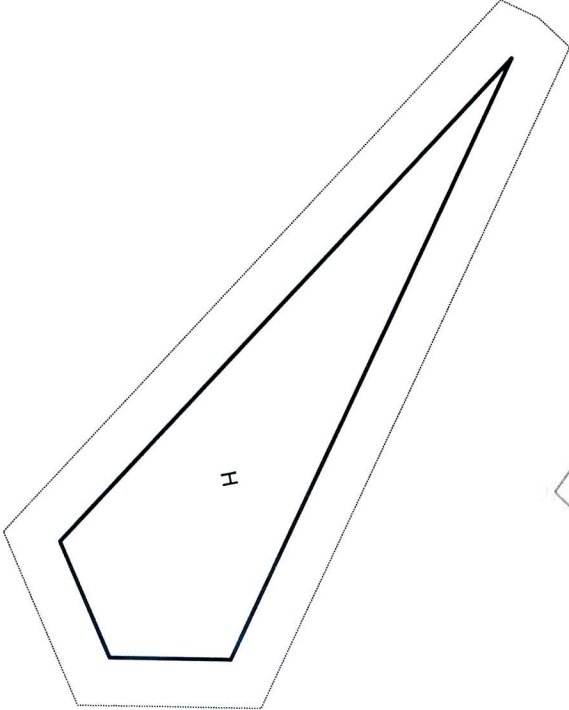
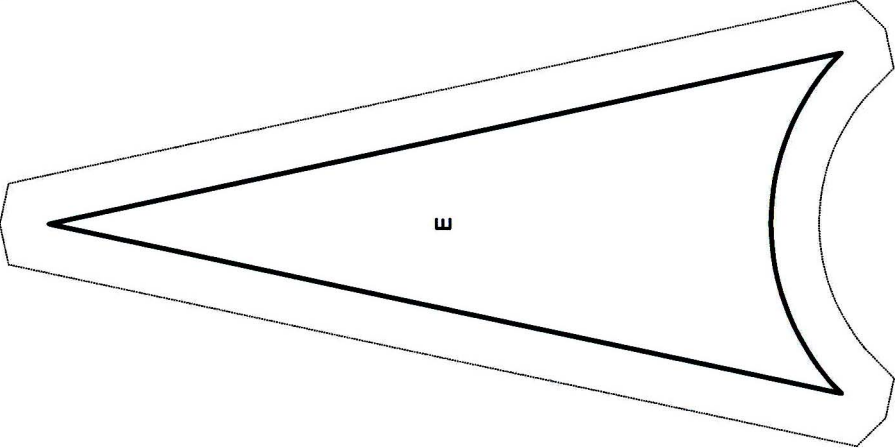
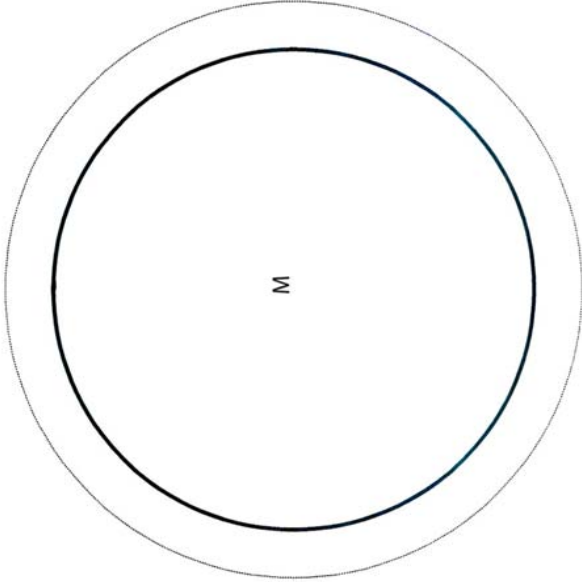

Paper Piecing for Compass

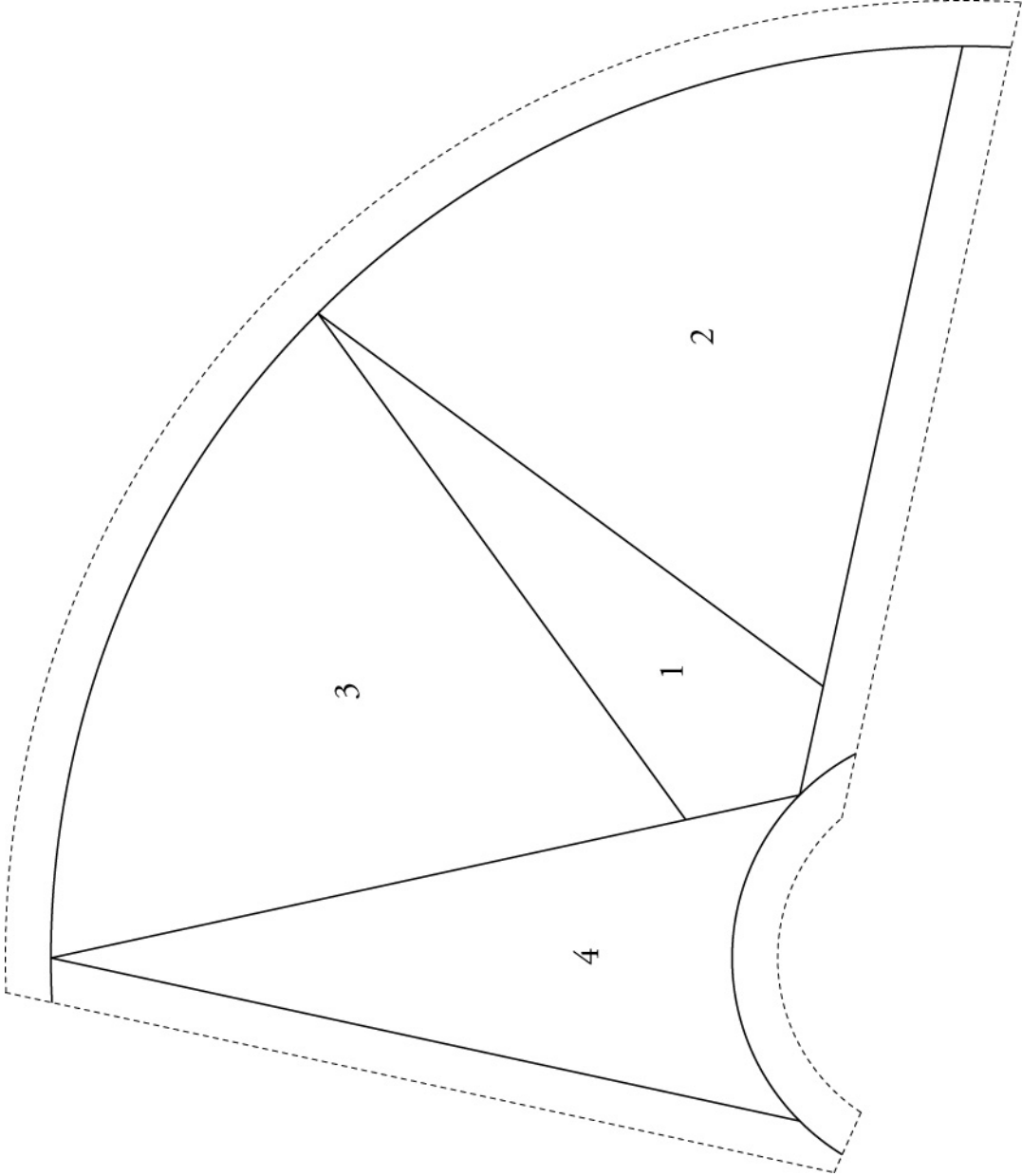

Template Design for Sailboat

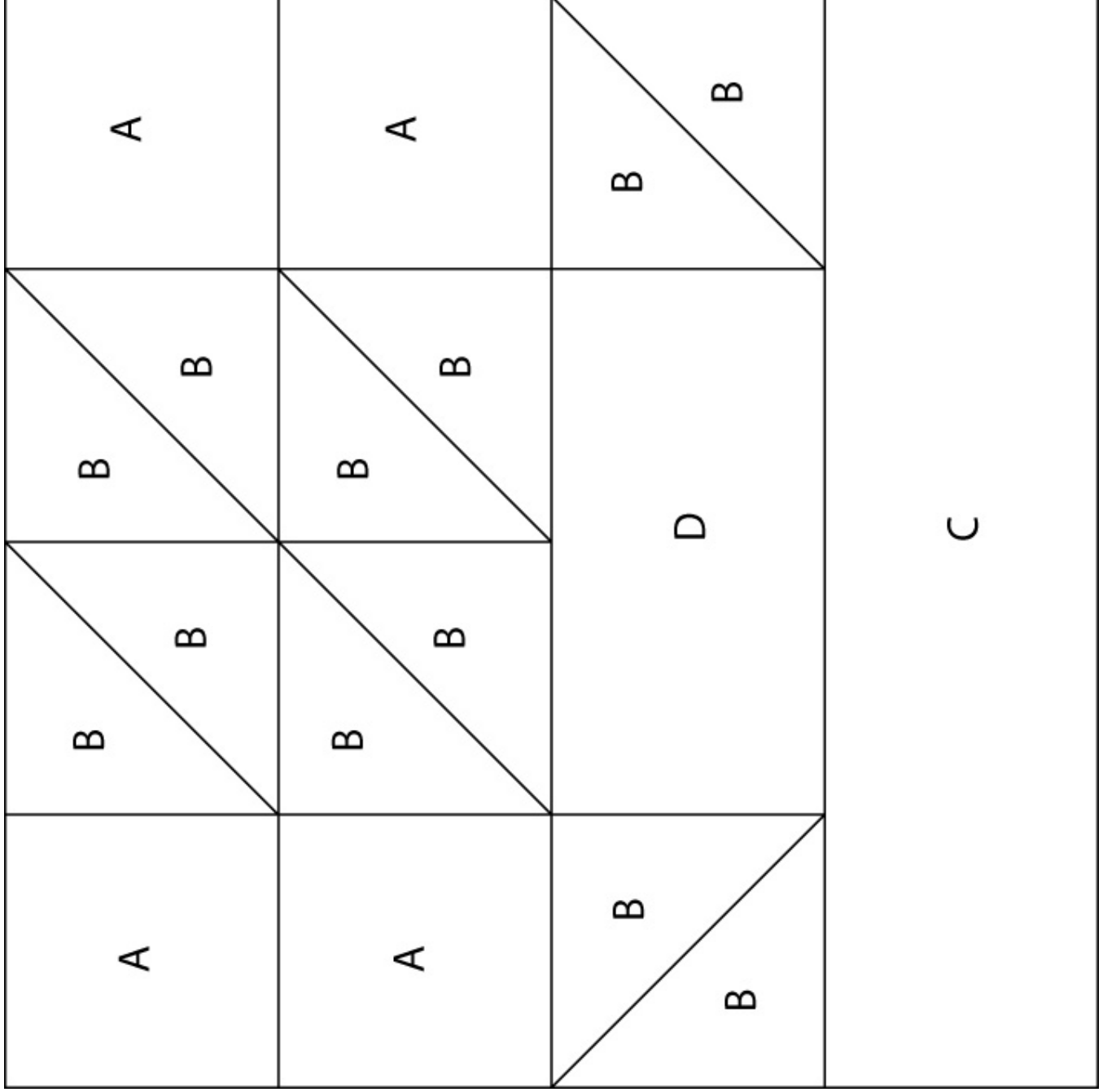

A

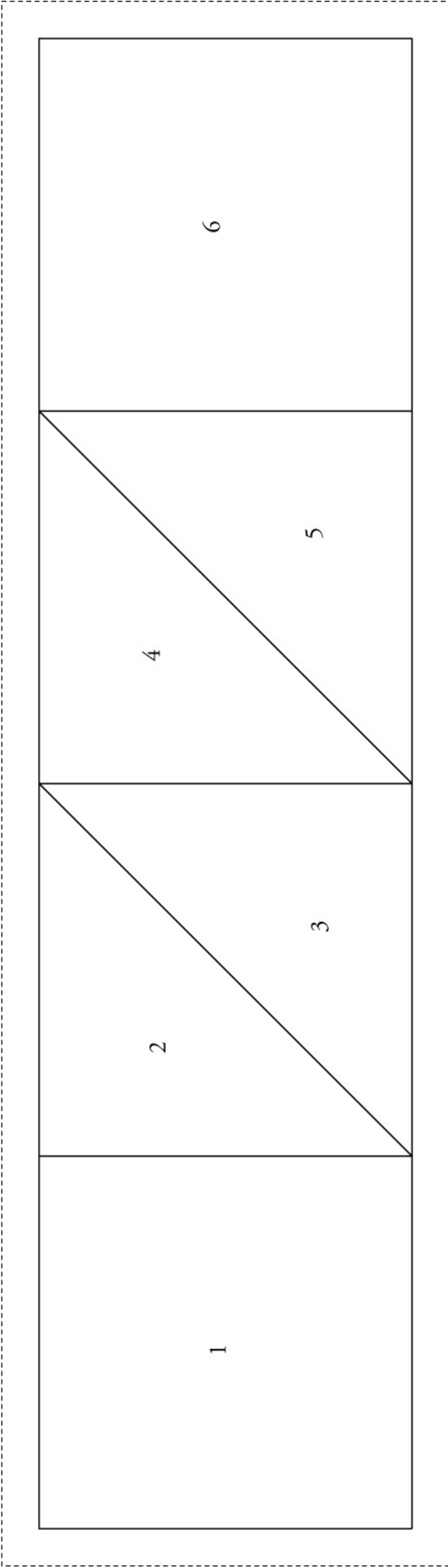

B

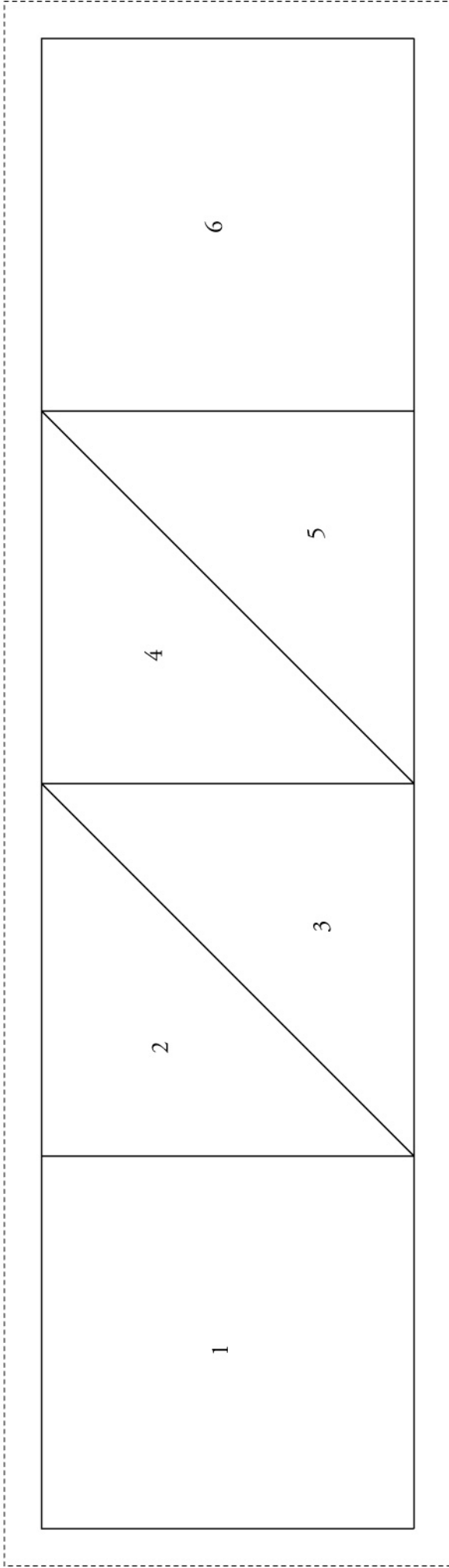

C

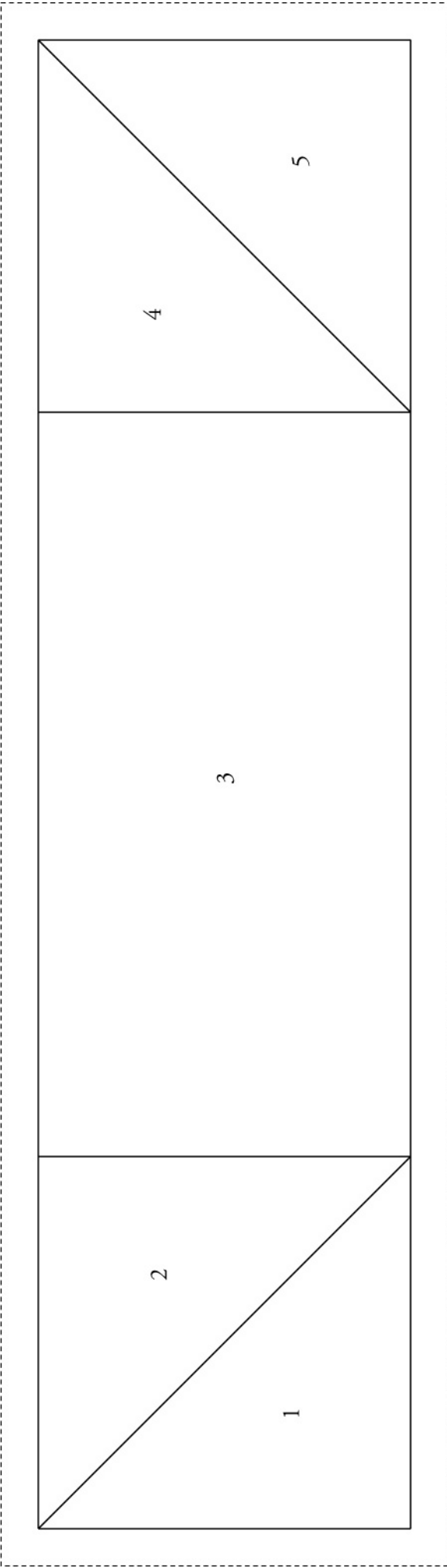

D

